

Technical information

MOBISCREEN MSC 952i EVO

MOBISCREEN MSC 953i EVO



Track-driven screening plants

Use in natural stone and recycling

MOBISCREEN MSC EVO

Series

HIGHLIGHTS

- > Classifying screening plant
- > Mobile double-deck screening unit (MSC 952i EVO)/
triple deck screening unit (MSC 953i EVO)
- > Screen casing size 102 ft²
- > Maximum feed size 7" x 4" x 3"

Mobile classifying screening plants MOBISCREEN MSC EVO

The mobile screening plants MOBISCREEN MSC 952i/953i EVO are equipped with a 102 ft² screen casing. The double- or triple-deck classifying screens impress with a feed capacity of up to 551 US t/h and thus meet the highest output demands.



TECHNICAL DATA - US SPEC	MSC 952i EVO	MSC 953i EVO
Feeding unit		
Feed capacity up to approx. (US t/h)	551	551
Max. feed size	7" x 4" x 3"	7" x 4" x 3"
Feed height - foldable slotted grate	11' 9"	11' 9"
Hopper volume (yd ³)	10.5	10.5
Hopper discharge conveyor		
Width x Length	48" x 11' 6"	48" x 11' 6"
Feeding conveyor		
Width x Length	48" x 39' 4"	48" x 39' 4"
Screening unit		
Type	Double-deck classifying screen	Triple-deck classifying screen
Width x Length	5' 1" x 20'	5' 1" x 20'
Fine grain discharge conveyor		
Width x length (extended)	48" x 26' 7"	48" x 26' 7"
Discharge height approx.	10' 10" - 14' 9"	10' 10" - 14' 9"
Discharge conveyor overflow lower deck (medium grain)		
Width x Length	32" x 33' 6"	32" x 33' 6"
Discharge height approx.	16' 5"	16' 5"
Discharge conveyor overflow centre deck (medium grain)		
Width x Length	-	32" x 33' 6"
Discharge height approx.	-	16' 5"
Transfer conveyor		
Width x Length	-	2' 2" x 5' 11"
Discharge conveyor overflow upper deck (oversize grain)		
Width x Length	32" x 33' 6"	20" x 29' 2"
Discharge height approx.	16' 5"	16' 6"
Power supply unit		
Drive concept	diesel-hydraulic	diesel-hydraulic
Power pack manufacturer (Tier 4f/stage IV)	John Deere	John Deere
Power supply unit output (hp)	131	131
Transport position dimensions		
Height approx.	11' 1"	11' 1"
Length approx.	58' 11"	58' 11"
Width approx.	9' 10"	10' 6"
Transport weight basic system - max. equipment approx. (lbs)	77,100 - 87,750	85,500 - 96,150

OPERATING POSITION MSC 952i EVO

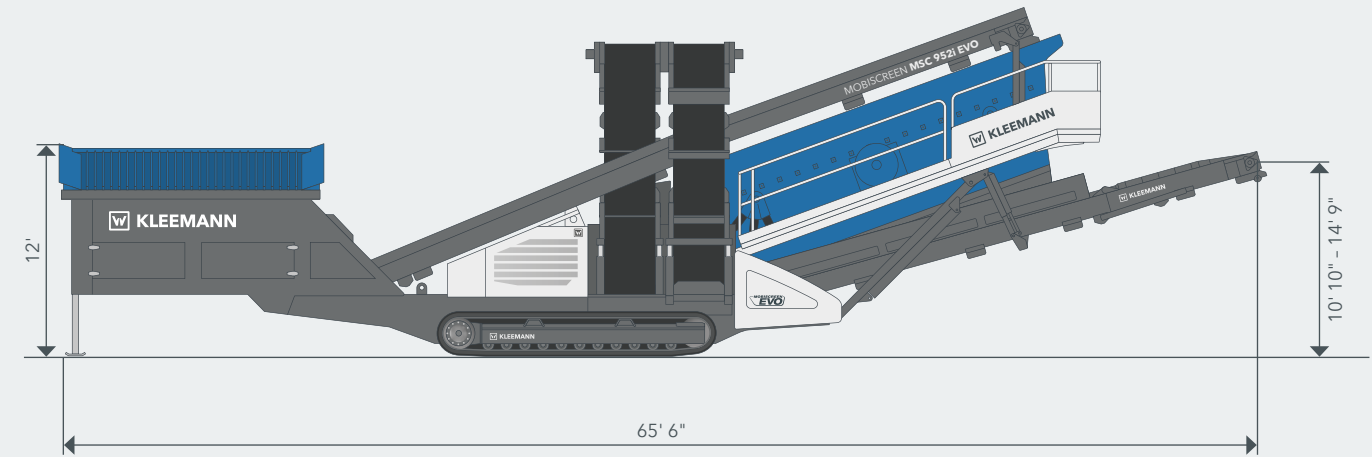

MATERIAL FLOW MSC 953i EVO

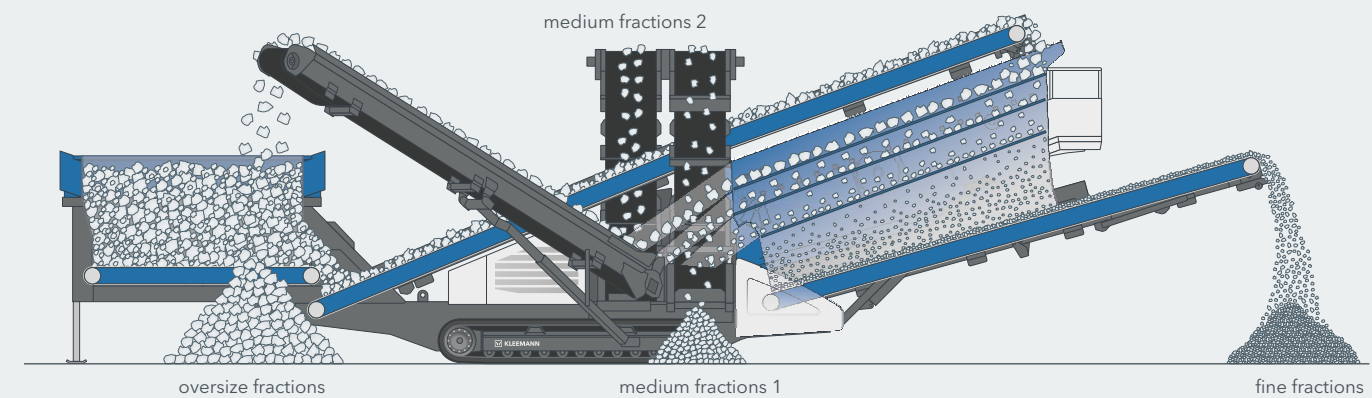

Thanks to compact transport dimensions, short set-up times and a large selection of screen surfaces, the classifying screening plants MSC EVO can be used flexibly. For efficient processing of large volumes, the design of the material flow has been optimized: starting with the feed hopper that widens in the material direction of flow, to the wide feeding

conveyor and on to the generously dimensioned screening surface. Operation is via an intuitive mobile operating device that can be inserted at three points on the machine. All functions can therefore be controlled simply from a safe distance and operating statuses and machine functions can be viewed easily at all times.

STANDARD EQUIPMENT

- > Double-deck classifying screen (MSC 952i EVO),
Triple-deck classifying screen (MSC 953i EVO)
- > Hopper unit 10.5 yd³
- > Foldable slotted grate, gap width 4", hydraulic folding
(remote control, small)
- > Feeding conveyor, smooth belt
- > Dosing flap on hopper unit for continuous material flow
- > Feeding conveyor material brake to prevent material from rolling
back
- > Screen material brake prevent feed material from jumping over
from the upper deck
- > Removable, wired machine control system used for controlling all
driving and movement functions, adapting settings and reading out
machine data and troubleshooting aids
- > Telematics system WITOS FleetView for efficient Fleet and Service
Management

OPTIONS

- > Hopper unit 13 yd³
- > Wear lining made from wear-resistant steel (KRS) or rubber
(for 10.5 yd³ and 13 yd³)
- > Vibrating slotted grate for separating feed material, gap width
of upper deck 4", clear mesh size of lower deck 1.26" - 3.54"
- > Cleated feeding conveyor prevents material from rolling back
- > Oversize grain conveyor of the MSC 953i EVO can be configured on
the left or right (retrofit not possible)
- > Belt cover for the feeding conveyor or fine grain discharge conveyor
- > External power supply - for efficient mains operation, possible to
change between two energy sources: own propulsion (diesel engine)
or external power supply
- > Start-stop system for low consumption in idle phases
- > Radio remote control: crawler chassis, automatic folding function
of the slotted grate, hopper discharge conveyor On/Off and speed
setting, emergency stop
- > Remote control for foldable slotted grate, in addition to cable
control (omitted if plant has radio remote control)
- > Line coupling for interlinking with other KLEEMANN plants
- > Large selection of screen surfaces for all decks with different clear
mesh sizes
- > Anti-clogging ropes for use with sticky material
- > Water spray system for dust reduction
- > LED lighting



Economic operation of the machine also requires choosing the correct wear parts. KLEEMANN original parts are ideally tuned to the requirements of users and machines. Thanks to our application know-how and expert advice, we help our customers to find the optimal wear part for their individual application. Further information: parts.wirtgen-group.com

WIRTGEN AMERICA

6030 Dana Way
Antioch, TN 37013
USA

T: +1 615 501 0600
M: info.america@wirtgen-group.com

www.wirtgen-group.com/america

