

Technical information

MOBIREX MR 100i NEO

MOBIREX MR 100i NEOe



Track-mounted impact crusher

For use in recycling and natural stone

MOBIREX NEO

Series

HIGHLIGHTS

- > Very compact design makes transport easy
- > Two drive concepts available: E-DRIVE diesel-electric drive / D-DRIVE diesel-direct drive
- > Diesel-electric, connection to external power supply
- > Fully hydraulic gap adjustment and overload system
- > High-performance post screening unit with large screening surface

The MOBIREX MR 100i NEO and MR 100i NEOe mobile impact crushers

Thanks to their compact dimensions and low transport weight, the MOBIREX MR 100i NEO/NEOe can be used flexibly, quickly and in a very wide variety of applications - making it ideally suited for frequently changing work locations.

The version with the E-DRIVE electric drive concept, with its option for an external power supply, enables local CO₂-emission-free operation.



TECHNICAL DATA MR 100i NEO | MR 100i NEOe

Feeding unit ¹⁾	
Feed capacity up to approx. (US t/h)	276
Max. feed size	20" x 32" x 12"
Feed height	10' 6"
Width x length	6' 7" x 7' 7"
Hopper (yd ³)	4.3
Prescreening	
Type	Integrated prescreening (single-deck)
Width x length	2' 9" x 5' 6"
Side discharge conveyor	
Width x length	20" x 12' 10"
Discharge height	7' 10"
Crusher	
Impact crusher model	SHB100-075
Crusher inlet width x height	40" x 30"
Rotor diameter	39"
MR 100i NEO: Crusher drive type	direct
MR 100i NEOe: Crusher drive type	Electric
Crusher output up to (hp)	hp
Type of impact toggle adjustment	infinitely variable, fully hydraulic
Crusher discharge conveyor	
Width x length	40" x 27"
Discharge height approx.	11'

E-DRIVE power supply unit (MR 100i NEOe)	
Drive concept	Diesel-electric
Output (hp)	268
Power pack manufacturer	John Deere
Generator (kVA)	260
D-DRIVE power supply unit	
Drive concept	diesel-direct ²⁾
Output (hp)	268
Power pack manufacturer	John Deere
Generator (kVA)	88
Post screening unit	
Type	Single-deck post screening unit
Width x length approx.	4' 5" x 10' 2"
Return conveyor width x length	20' x 24' 3"
Discharge height fine grain discharge conveyor approx.	9' 4"
Transport	
Transport height approx.	10' 6"
Transport length approx.	41' 11"
Transport length with screening unit approx.	48' 10"
Transport width approx.	8' 4"
Transport width with screening unit max.	9' 8"
Transport weight basic equipment approx. (lbs)	64,050
Transport weight max. configuration approx. (lbs)	82,800
Transport weight of screening unit approx. (lbs)	12,130

¹⁾ incl. integrated vibrating feeder and prescreening
²⁾ all electric auxiliary drives

OPERATING POSITION

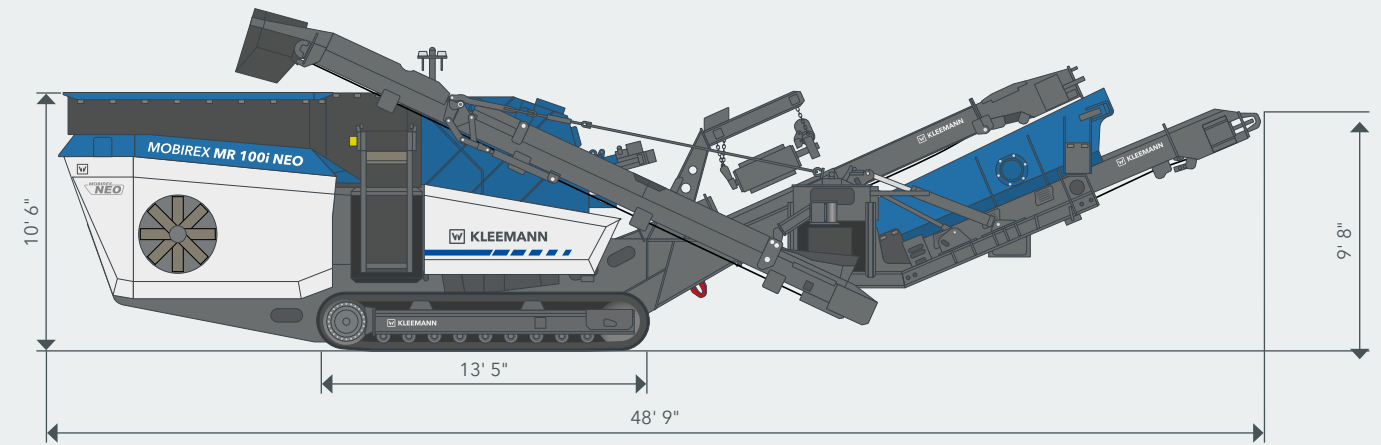

MATERIAL FLOW

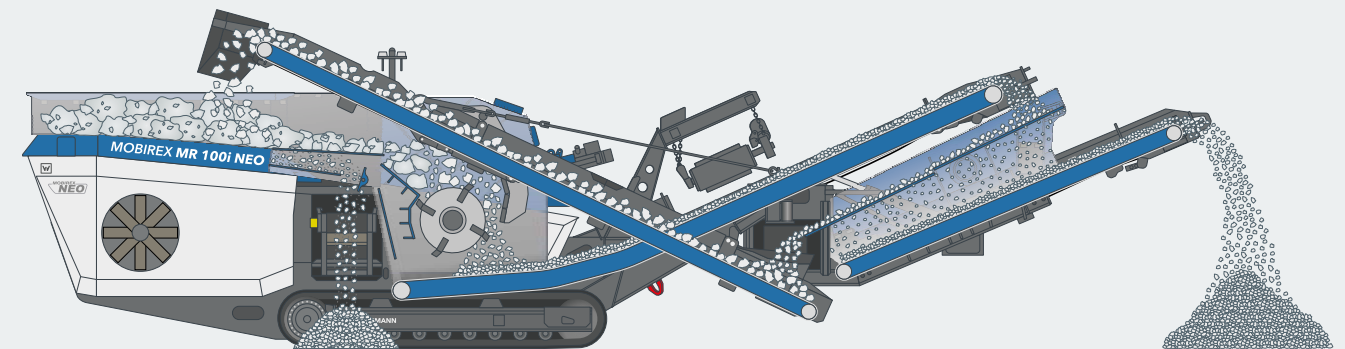

The MR 100i NEO/NEOe stands out with its very high final product quality. This is guaranteed not only by the powerful crushing unit with its 4-legged rotor with a large impact range and versatile rotor ledge variants, but also by the 5" x 10' 2" large, single-deck post screening unit. This enables the production of a classified final grain size. Thanks to integrated oversize grain returning,

the post screening unit is designed such that it can be easily retrofitted via "plug & play". The use of the optional wind sifter can further optimize the final product quality by removing contamination in the material such as lightweight wood and plastic. The air flow can be easily controlled depending on the material.

STANDARD EQUIPMENT

- > Hopper-vibrating feeder with integrated prescreening and frequency-controlled material transport
- > Continuous Feed System (CFS) for optimum crusher loading
- > Fully hydraulic crusher gap adjustment
- > Automatic zero-point determination for precise gap setting via operating position
- > Integrated overload protection
- > Lock & Turn (rotor turning and locking device): Simple and safe rotor ledge replacement and breaking up of material bridging via a separate SPECTIVE operating position, fast tool-free opening and closing of the crusher in approx. 30 seconds
- > **MR 100i NEOe: External power supply for local CO₂-emission-free mains operation**
- > Operating concept: SPECTIVE operating position: simple adjustment of machine parameters; telematics system for efficient fleet and service management
- > Radio remote control: Moving and setting up the machine, simple adjustment of the operating parameters (e.g. crusher gap setting)
- > LED lighting
- > Water spray system for reducing dust
- > Permanent magnet, attached flexibly by means of chains, adjustable transverse and longitudinal inclination, can be lifted and lowered hydraulically
- > Single-deck post screening unit for the production of a classified final grain size, with integrated swivel return conveyor
- > SPECTIVE CONNECT for displaying all important machine information directly on the smartphone, additional troubleshooting aids in the app

OPTIONS

- > Side discharge conveyor, hydraulically foldable, remains on machine for transport
- > Liftable crusher inlet box cover for less material bridging in the inlet area
- > Lifting device for changing rotor ledges
- > Belt scale, available for fine grain conveyor
- > Wind sifter for cleaning oversize grain to remove foreign matter and lightweight material
- > Quick Track for selecting machine operating mode quickly and easily, operation via radio remote control
- > Water pump with pressure monitoring
- > Premium lighting
- > Simple refuelling from the ground through refuelling pump
- > Rear collision guard for protection of the power pack chamber

WIRTGEN AMERICA

6030 Dana Way
 Antioch, TN 37013
 USA

T: +1 615 501 0600
 M: info.america@wirtgen-group.com

www.wirtgen-group.com/america

