



Mobile impact crusher

**MOBIREX**

**MR 100i NEO | MR 100i NEOe**





# A LONG HERITAGE OF EXPERTISE

Efficient crushing and screening plants.

For the past 100 years, KLEEMANN GmbH has been developing and manufacturing machines and plants for the natural stone and recycling industry.

High levels of performance and innovative details, simple handling and maximum safety for the operator - and always with a focus on sustainability. This is what KLEEMANN crushing and screening plants stand for.

## THE KLEEMANN PRODUCT RANGE

**MOBICAT**  
Mobile jaw crushers

**MOBIREX**  
Mobile impact crushers

**MOBICONE**  
Mobile cone crushers

**MOBISCREEN**  
Mobile screening plants

**MOBIBELT**  
Mobile stackers

Over 100 years of  
tradition

**A WIRTGEN GROUP Company**  
An internationally active group of companies



With more than 200  
subsidiaries and dealers in Germany and abroad

**KLEEMANN**



# MOBIREX MR 100i NEO | MR 100i NEOe

From A to B with unmatched efficiency.

**The MOBIREX MR 100i NEO compact impact crusher is efficient, powerful, flexible in its application and impresses with its simple operability.**

Regardless of how limited space on the job site may be, thanks to its compact dimensions and a low transport weight, deployment of the MOBIREX MR 100i NEO/NEOe is flexible, fast and highly versatile. Its operation ranges from different recycling applications, such as the processing of concrete, mixed rubble and asphalt, to the processing of soft to medium-hard natural stone. Thanks to its compact design, the machine is especially well suited for use in urban mining - i.e. directly at inner-city construction sites.

## An eye on sustainability

The new impact crusher from KLEEMANN is available in two drive versions. Depending on the field of application, it is possible to operate the machine purely electrically and therefore locally emission-free thanks to the E-DRIVE drive concept (MR 100i NEOe). Alternatively, the machine is available with the tried-and-tested D-DRIVE diesel-direct drive with maximum efficiency.

## Simple plant operation

Machine operation is simple and intuitive directly at the SPECTIVE SWITCH Panel. With SPECTIVE CONNECT, operators have relevant data on speed, consumption values and fill levels at their fingertips on a smartphone or tablet prepared in a clearly arranged manner.

SPECTIVE CONNECT also offers detailed troubleshooting aids to assist with service and maintenance. A unique feature in this machine class is the fully hydraulic crusher gap adjustment and zero-point determination. The latter compensates for wear during crusher start and ensures a constant crushing product.



Focus on  
flexibility



Operability in  
the foreground



An eye on  
sustainability



MOBIREX  
**NEO**



# THE HIGHLIGHTS

Perfectly equipped.

## 01 Feeding unit and prescreen

> Hopper-vibrating feeder with integrated prescreening

## 02 CFS (Continuous Feed System)

> Continuous crusher utilization thanks to CFS

## 03 Crusher unit

> Powerful electrically driven crusher with fully hydraulic gap adjustment and overload system  
> Simple tool-free opening and closing of the crusher "Lock & Turn Quick Access"

## 04 Drive

> Two drive concepts available:  
MR 100i NEO - D-DRIVE (diesel-direct)  
MR 100i NEOe - E-DRIVE (diesel-electric drive)

## 05 Operating concept

> Simple operating concept thanks to the SPECTIVE SWITCH  
> With SPECTIVE CONNECT, all important information is available directly on the smartphone

## 06 Post screening unit and magnetic separator

> Effective single-deck post screening unit for the production of a classified final grain size  
> Efficient permanent magnet for increased final product quality and high plant performance

## > Safety & ergonomics

> Fast and ergonomic servicing thanks to excellent accessibility to all components

## > Transport

> Outstanding flexibility facilitates changing locations and fast set-up times

## > Environmentally sound solutions

> Local CO<sub>2</sub> emission-free operation through external power supply with E-DRIVE drive concept  
> Reduced dust and noise



**KLEEMANN**  
SUSTAINABILITY

KLEEMANN SUSTAINABILITY describes innovative technologies and solutions which are consistent with the sustainability objectives of the WIRTGEN GROUP.



# COMPACT FEEDING UNIT

With effective integrated prescreening

The MOBIREX MR 100i NEO is equipped with a hopper-vibrating feeder to ensure compact design.

The compact impact crusher's hopper-vibrating feeder features integrated prescreening. Powerful electric vibrating chute motors ensure a continuously high conveying capacity.

Prescreening scores with a high screening capacity with an enlarged screening surface thanks to an optimized slotted grate and hexagonal punched plates. Fine material is separated from the feed material and does not have to run

through the crusher. It is either directed through the crusher bypass past the crusher or discharged by the optional side discharge conveyor.

Thanks to the bypass, a rapid changeover of the material flow – discharge via the side discharge conveyor or bypass – is possible. This guarantees better results and less wear.

**up to 276 US t/h**  
Feed capacity

**20" x 32" x 12"**  
max. feed size

**approx. 4.3 yd<sup>3</sup>**  
Hopper volume



The side discharge conveyor installed on the right side can be folded hydraulically and can therefore remain on the machine for transport.

### Optimized output capacity - thanks to well prepared feed material

The composition of the feed material and the feed size greatly impact the output capacity. To guarantee trouble-free and low-wear operation, the feed material should therefore be prepared as well as possible.

### Tips on optimal loading

- > Take note of the size and edge length of the material
- > Select feed size depending on the final grain size and max. permissible reduction ratio
- > Sort out any uncrushable material, e.g. steel beams, cable, wood, films/foils
- > Guarantee uniform loading of the plant - an overfilled feed hopper and a continuously empty feed hopper can lead to increased wear

## KLEEMANN > PROCESS KNOWLEDGE

In many cases, feed capacity, crushing capacity and plant performance are treated synonymously or even mixed up. What's what?

Crushing capacity  
= Quantity produced by the crusher ■

Feed capacity  
= Crushing capacity ■ + prescreening capacity ■ + bypass capacity ■

Plant performance  
= Crushing capacity ■ + bypass capacity ■

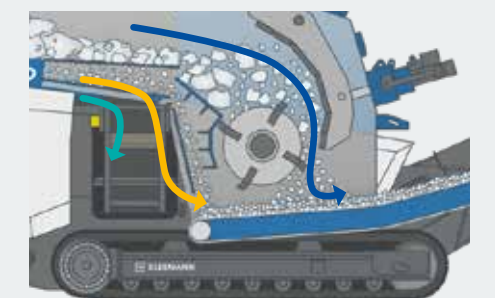

# CONTINUOUS FEED SYSTEM (CFS)

For a continuous crusher feed.

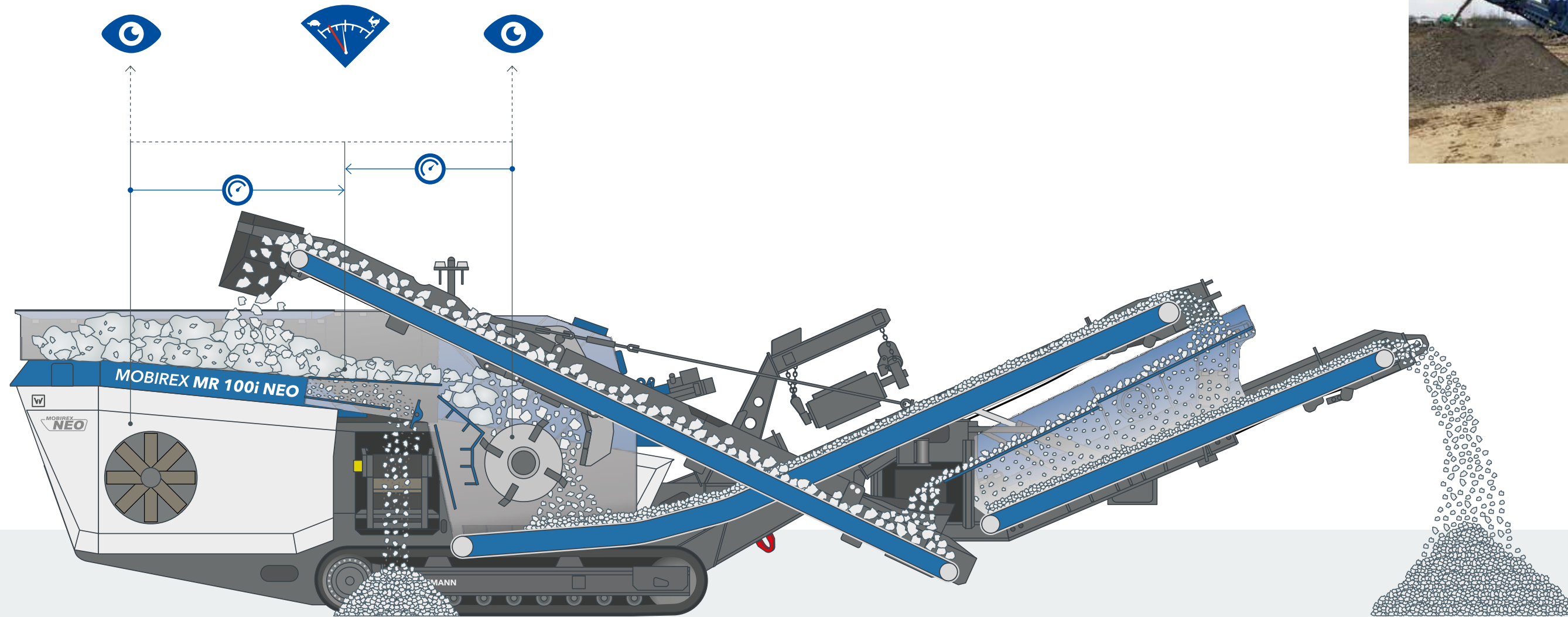

## Uniform material flow is indispensable for a good final product, optimum throughput and low wear.

To ensure that the crushing chamber is always filled evenly, the continuous feed system (CFS) monitors the load on the rotor and engine utilization. Independently of this, the CFS regulates the frequency of the vibrating feeder. A backlog on the feeding unit can be avoided and crusher utilization is optimized.

Once the crushing chamber is cleared after an overload, material conveying continues without delay. The CFS facilitates the operator's work, as the machine automatically ensures an even material flow and therefore optimum feeding of the crusher.

## KLEEMANN > GOOD TO KNOW

### Intelligent material conveyance in the compact class

The Continuous Feed System (CFS) is a unique feature in the compact class and enables inexperienced operators to achieve high utilization of the crusher. This leads to less material bridging and fewer machine downtimes. By means of uniform loading or regulation and no hard "Start/Stop" as with other systems, the machine components are protected and fuel consumption is kept to a minimum.



# POWERFUL CRUSHER UNIT

The heart of the machine.

The crusher unit of the MR 100i NEO / NEOe is the core element of the machine and impresses with its 4-ledged rotor with large impact circle and its automatic zero-point determination.

Very high product quality is expected from an impact crusher, and this is precisely what the "compact crusher" delivers. This is guaranteed, above all, by the powerful crusher unit with

its 4-ledged rotor with a large impact range and versatile rotor ledge options.



The inlet geometry of the crusher unit guarantees optimum feed behaviour of the material. All of this along with the generously dimensioned passage **A** under the crusher guarantees the best possible material flow, which, in turn, ensures a high throughput. The tried-and tested C-shape rotor ledges guarantee a high product quality and a very high impact effect over a long period. Wear parts can be changed easily and safely from above. Thanks to a liftable inlet flap **B** (optional), material bridging in the inlet area is easy to break up.



**40" x 30"**  
Crusher inlet

**Effective overload system**  
to protect the plant

**Fully hydraulic**  
Gap setting



**Comfortable operation: Zero-point determination and gap setting**

A unique feature in the compact class is the fully automatic zero-point determination and gap setting with the MR 100i NEO. This is carried out conveniently at the push of a button via SPECTIVE SWITCH. The zero-point determination compensates for wear during crusher start and ensures a constant crushing product. The crusher gap setting can be made simply by pushing a button in mm increments.

**Effective overload system for protecting the machine**

If there is too much material in the crusher, or it is too coarse, the impact toggle gives way slightly, allowing the material to pass through for a short time. The rocker then moves back automatically to the preset value

In case of **uncrushable elements**, such as large ferrous parts, the overload system is tripped. The pressure plate then breaks allowing the rocker to move out of the way. This protects the rotor, rocker and crusher housing against serious damage.



01 Zero-point determination and gap setting  
02 Operation via SPECTIVE SWITCH  
03 Effective overload system



**Innovative: Lock & Turn Quick Access**

The tool-free opening of the crusher is another great feature of the compact impact crusher. "Lock & Turn Quick Access" allows customers to open the crusher very quickly at the push of a button. The crusher can be opened or closed in only

30 seconds. In next to no time, operators can safely view the complete crushing chamber, for example, to break up material bridging or to change a rotor ledge.

**LOCK & TURN QUICK ACCESS - STEP BY STEP**



> The rotor locking and turning device is released at the touch of a button...  
...and engaged by hand crank.



> The crusher is unlocked at the push of a button...  
...and the wedges for locking the crusher housing are pulled hydraulically.



> Automatic opening of the crusher housing when the button is held down...  
...until the crusher opens completely. The mechanical safety catch also engages.



> The rotor is moved into position for wear check or rotor ledge replacement.  
The crusher is opened completely for best possible access for service and maintenance from both sides. Rotor ledge replacement takes place easily from above.



# SUSTAINABLE DRIVE CONCEPTS

Top performance - efficient and environmentally-friendly.



**A further main component of a crushing plant is its drive. It is a contributing factor for the efficiency of a machine as well as fuel consumption.**

The MR 100i NEO is available in two versions - with the E-DRIVE or D-DRIVE drive concept.

The machine can be configured to suit the application area and existing infrastructure.

## MR 100i NEOe with E-DRIVE drive concept

As an "e-variant", the small mobile impact crusher is equipped with the E-DRIVE diesel-electric drive concept and has a connection to an external power supply. It is possible to operate the machine all-electrically and on site with CO<sub>2</sub>-free emissions. But operation via the on-board diesel generator is also possible at any time, so that you are prepared for all eventualities.

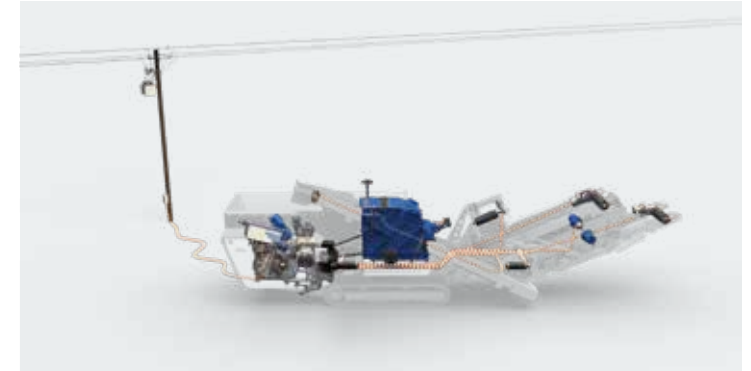

## MR 100i NEO with D-DRIVE drive concept

Alternatively, the machine is available with the tried-and-tested crusher direct drive (D-DRIVE) for maximum efficiency. It excels with very low fuel consumption, whereby all auxiliary drives are powered electrically.

### **i** Twice as good for the environment

If the plant is operated via the diesel generator, the load-dependent fan reduces not only the fuel consumption but also the noise emission.

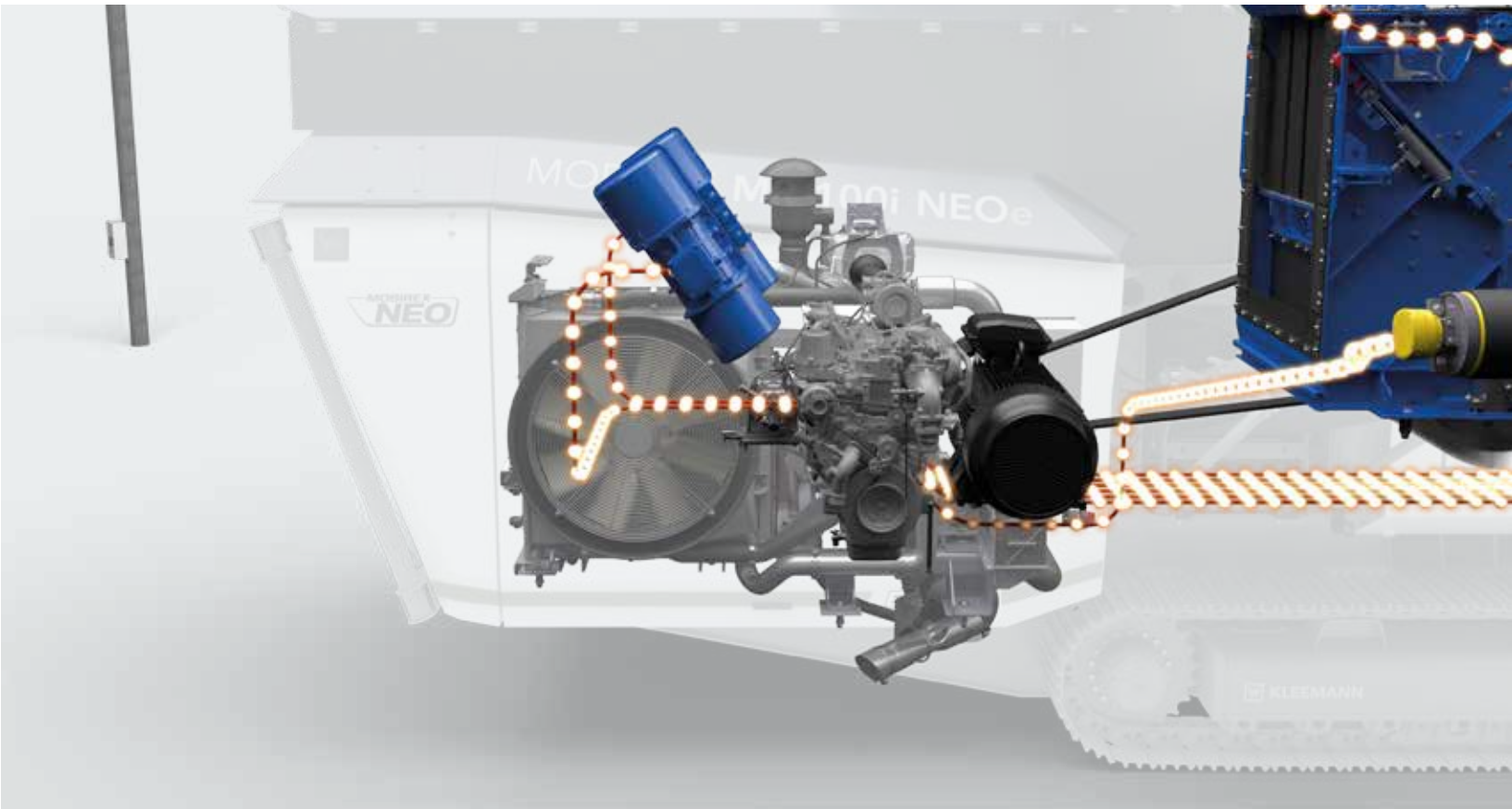
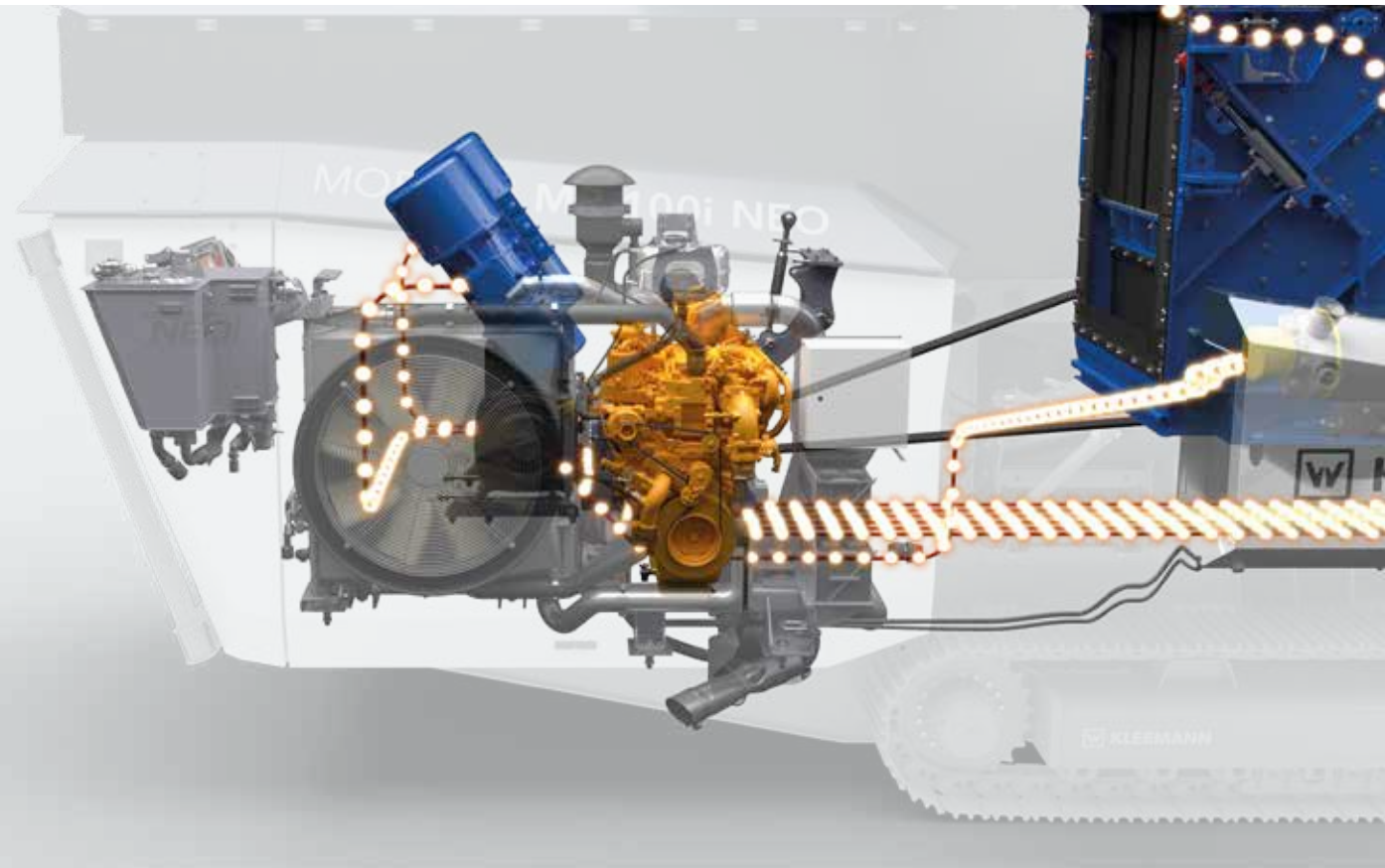

**Engaging the coupling**  
via push button (on with D-DRIVE)

**268 hp**  
output

**CO<sub>2</sub>-free operation**  
through an external power supply (MR 100i NEOe)



# SPECTIVE INTUITIVE OPERATING CONCEPT

For a better result.

The MR 100i NEO has a high degree of automation - for shorter start-up procedures and a lower risk of incorrect operation.

SPECTIVE SWITCH **01** makes machine operation simple and intuitive directly at the panel. The high degree of automation also guarantees a reduced scope of setting options.

With SPECTIVE CONNECT **02**, operators have all relevant data on speed, gap setting and crusher utilization as well as

consumption values and fill levels at their fingertips - on a smartphone or tablet, prepared in a clearly arranged manner. SPECTIVE CONNECT also offers detailed troubleshooting aids to assist with service and maintenance.



## IT'S AS SIMPLE AS THAT WITH SPECTIVE CONNECT



1. Connect the MR 100i NEO with SPECTIVE CONNECT by simply scanning the access data from the machine's display.



2. Extensive troubleshooting aids are displayed directly "in the palm of your hand".

## Operation from a safe distance

The large radio remote control **04** allows operation of all plant functions, including the complete set-up and driving operation, from a safe distance. When it has been set once and put into operation in automatic mode, for most procedures the operator no longer has to go to the plant. Another advantage in the field is the long battery life (> 10h) with LED for battery status display and a battery change without an emergency stop.

The small radio remote control **03** (optional) is suitable for carrying in the loading device thanks to its compact size. All relevant functions can therefore be operated in automatic mode conveniently from the excavator or wheel loader. The small radio remote control is the ideal supplement to SPECTIVE CONNECT.

## KLEEMANN > GOOD TO KNOW

### Always in operation with "Quick Track"

In some applications - for example in road construction - relocation of the crushing plant several times a day is necessary. When this is done, the plant should remain in operating mode so that it is quickly ready for operation once it has been moved. The "Quick Track" option allows this to be controlled conveniently via the remote control - without leaving the operating mode.

There is no need for the operator to access the machine, change operating mode, interrupt machine operation or restart it afterwards. This saves time and allows the machine to continue working quickly and productively.



# POST SCREENING UNIT AND MAGNETIC SEPARATOR

Ensures the best possible final product.

**The MR 100i NEO has an single-deck post screening unit for the production of a classified final grain. Furthermore, the plant can be equipped with an efficient permanent magnetic separator.**

## Production of a classified final grain size

The large single-deck post screening unit with a screening surface of 4' 5" x 10' 2" enables the production of a classified final grain size. Thanks to integrated oversize grain returning, the post screening unit is designed so that it can be easily retrofitted via "plug & play". Operators can therefore react flexibly to changing application areas.

The wide oversize grain returning system allows the material to be supplied in a closed loop to the crusher. The oversize grain conveyor can also be swivelled by 180° for material discharge onto the stockpile.

## Increase in final product quality

To prevent contamination of the final product with ferrous elements, a permanent magnetic separator can be installed. It can be attached flexibly to chains, which gives it a greater range of movement. Fast reactions in case of material congestion under the magnets are possible: It can be raised and lowered hydraulically by remote control. Material bridging can then be broken up every easily and the distance from the magnet to the belt can be set to its optimum value.

## Plant performance is measurable and transparent

An optional belt scale at the fine grain conveyor is available for the MR 100i NEO. It can be conveniently displayed in SPECTIVE CONNECT. The current production output can therefore be viewed at any time on the system's dashboard. Data is recorded in Reporting which allows conclusions to be drawn on plant output and utilization.

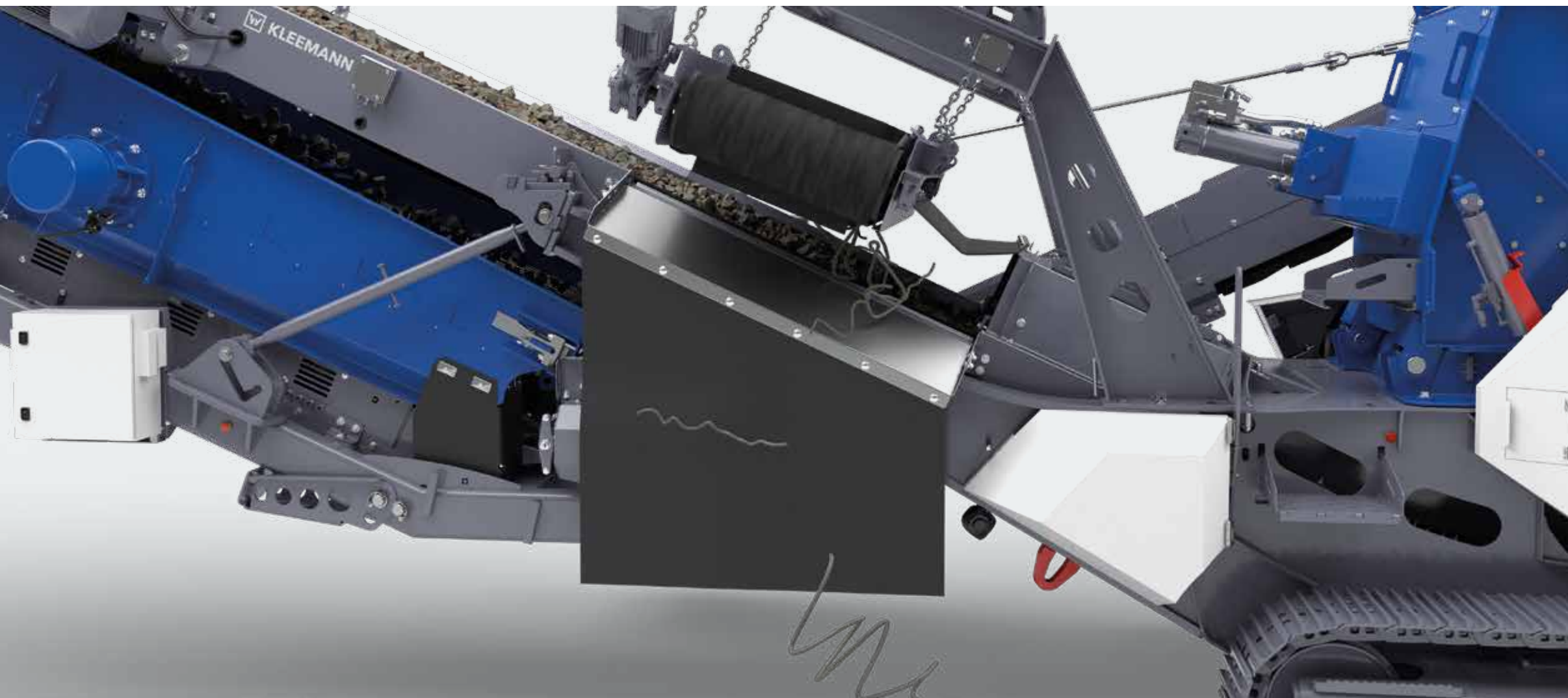

## KLEEMANN > PROCESS KNOWLEDGE

The optional wind sifters for cleaning the oversize grain guarantee increased material quality particularly in recycling because contamination through foreign bodies (e.g. wood and plastic) is removed from the material. The air flow can be easily controlled depending on the material. This reduces manual and sorting work. The wind sifter can only be used in conjunction with the post screening unit.



# SAFETY & ERGONOMICS

For superior operating comfort.

## The MOBIREX MR 100i NEO is easy to operate and comfortable to maintain.

All machine components of the MR 100i NEO, in spite of their compactness, are especially easy to access to guarantee trouble-free production, simple operation and fast service.

This is guaranteed, for example, by an ergonomic platform at the crusher inlet that provides a very good view of the feeding unit, as well as various steps and a safe climbing aid.

## Always convenient

The LED lighting ensures convenient and safe operation even in unfavourable light conditions. Option Premium lighting is also available for extended illumination of work areas. Thanks to the refuelling aid (optional), the plant can be filled conveniently from the ground. The engine compartment is generously dimensioned. The impeller's swivel-out function enables convenient cleaning and simple replacement of the fan. Coarse mesh cooler guarantees long cleaning intervals. For effective dust containment during operation, the impact crusher has spray systems at different transfer points.



● Standard lighting    + Premium lighting    □ Mobile work lamp

## Standard lighting

The standard lighting includes the illumination of the travel path, the steps and the area of the switch cabinet.

## Premium lighting

Premium lighting includes lighting of the power pack from all three sides, additional lamps for extended illumination of the machine environment and feeding unit, as well as a mobile maintenance lamp.



# EASY TRANSPORT

Quickly on site. Immediately ready for work.

**The compact impact crusher is versatile, compact and easy to transport.**

The MR 100i NEO can be used for many different types of applications and is quickly ready for operation. And even if the work location changes frequently, the machine is quickly transportable and also quickly loaded thanks to its relatively light weight. Due to its compactness, the machine is particularly suitable for use in urban mining – i.e. directly on site on inner-city building sites or similar areas.

After arrival at the work site, set-up times are very short:  
All belts such as the side discharge conveyor or return conveyor

can be conveniently moved hydraulically and moved safely into operating position with SPECTIVE radio remote control.

The post screening unit can remain on the machine for transport, although it can also be disassembled in a few minutes. Thanks to its compact dimensions, it can be easily transported separately.



**High flexibility**  
for changing work locations



**Short set-up times**  
thanks to uncomplicated set-up

**Weight**  
makes it easy to transport



# ENVIRONMENTALLY SOUND SOLUTIONS

For more sustainability.

The MR 100i NEO / NEOe is equipped with solutions to protect both the environment and the operator.

Thanks to its all-electric E-DRIVE concept with the option of an external power supply, the MR 100i NEOe "e-variant" can be operated on site free of CO<sub>2</sub> emissions. The following applies to both drive concepts, E-DRIVE and D-DRIVE:

Hydraulic oil is only required for setting and set-up functions, which reduces the environmental risk and minimizes maintenance costs.



**-10 dB noise reduction**  
through load-dependent fan

**Dust containment**  
through water spray nozzles



**KLEEMANN**  
SUSTAINABILITY

## Solutions for reducing noise and dust

If the plant is operated via the diesel generator, the load-dependent fan not only reduces fuel consumption but also noise emission.

Thanks to the water spray nozzles at all relevant positions such as the crusher inlet and discharge conveyors, most of the dust is bound together in the process, preventing it from spreading.



## KLEEMANN SUSTAINABILITY

### Hybrid solution for flexibility on site

If an external power supply is available, the MR 100i NEOe can be operated on site free of CO<sub>2</sub> emissions.

> Drive via diesel engine **A**

> Drive via external power source **B**

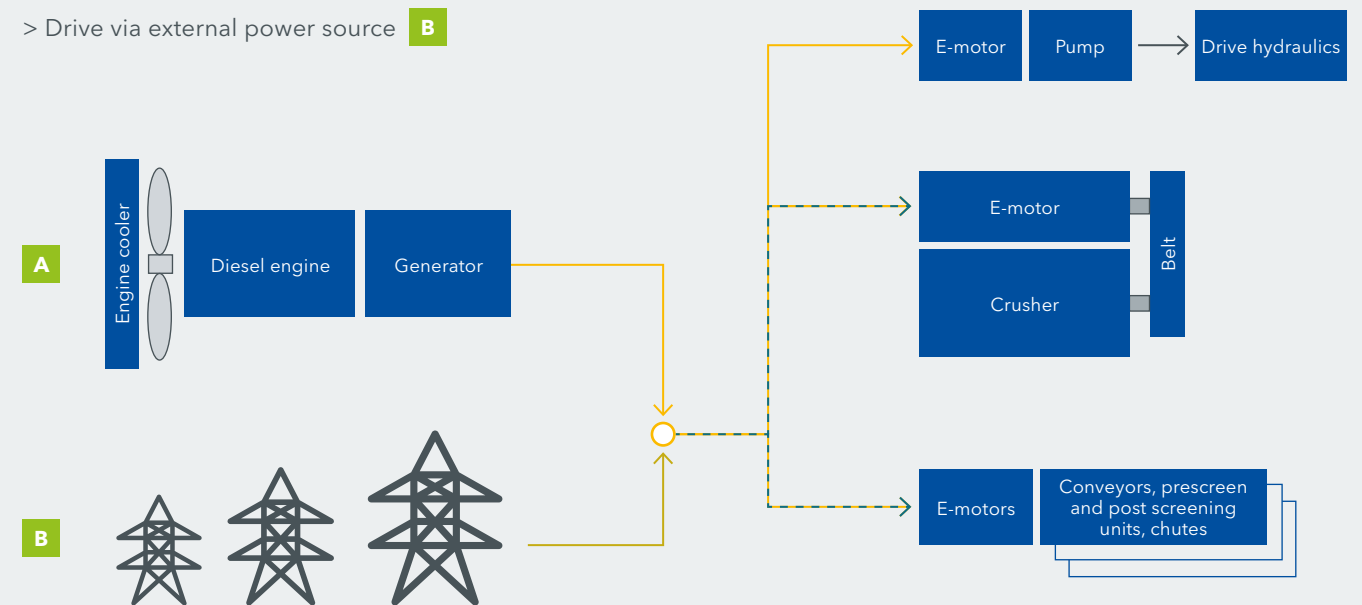



# FORMULA FOR SUCCESS

For perfect crushing results.

**An optimum crushing result can only be achieved with plant components that are perfectly tuned to one another - and the correct settings that the operator can choose himself.**

With these tips, it is possible to find the ideal settings for any task.

### Feed material

- > Feed size: where possible, the maximum feed size should not exceed 80% of the specified crusher opening
- > Compressive strength: Mineral materials can be used with a maximum compressive strength of 100 MPa in the 1st crushing stage, 150 MPa in the 2nd Crushing stage
- > Mineral type: Impact crushers from the SHB series process soft to medium-hard natural stone, such as limestone, dolomite or sandstone, and are used for recycling mineral raw materials such as mixed rubble, bricks, asphalt and concrete.

### Rotor speed and crushing gap

- > When the rotor speed is increased, the crushing curve shifts upwards, which results in an increase in the fines content in the end product.

An increase in speed usually results in a higher throughput. A throughput reduction only results if the feed behaviour is impaired by the increased impact frequency.

### Crushing ratio

- > The maximum crushing ratio (ratio of feed grain size / grain output) largely depends on the physical properties of the feed material. The following standard values result:

### REDUCTION RATIO STANDARD VALUES

Feed material	Compressive strength [MPa]	Circuit	Reduction ratio
Limestone, soft to medium-hard natural stone	<150	open	up to 10:1
		closed	
Recycling (rubble, asphalt, concrete)	< 100	open	up to 15:1
		closed	
Reinforced concrete (depending on concrete quality and iron content)	< 100	open	up to 15:1
		closed	

### Areas of application for impact crushing plants

#### NATURAL STONE

Coal / clay / marble / limestone	Sandstone, gritstone / greywacke	Gravel / granite	Basalt	Iron ore / gneiss / quartzite / diabase, gabbro
Asphalt / reinforced demolished concrete	Demolished concrete / mixed rubble		Blast furnace slag	Steel slag

#### RECYCLING

# YOUR WIRTGEN GROUP CUSTOMER SUPPORT

Service you can always rely on.

**Place your trust in our reliable and fast support during the complete life cycle of your machine. Our wide service offer includes suitable solutions to meet all of your challenges.**



### Service

We keep our service promises - with fast and uncomplicated assistance both on the building site and in our professional workshops. Our Service team has received expert training. Thanks to special tools, repair, care and maintenance work is completed quickly. Upon request, we can support you with tailored service agreements.

> [www.wirtgen-group.com/service](http://www.wirtgen-group.com/service)



### Spare parts

Original parts and accessories from WIRTGEN GROUP can ensure the high reliability and availability of your machines in the long term. Our experts will be glad to advise you on application-optimized wear part solutions. Our parts are available worldwide, at any time and are easy to order.

> [parts.wirtgen-group.com](http://parts.wirtgen-group.com)



### Training

Staff responsible for the WIRTGEN GROUP's product brands are specialists in their areas and have decades of application experience. Our customers also greatly benefit from these experts. In our WIRTGEN GROUP training courses, we gladly pass on our knowledge to operators and service personnel.

> [www.wirtgen-group.com/training](http://www.wirtgen-group.com/training)



### Telematics solutions

Construction machines with leading technology and perfected telematics solutions work hand-in-hand in the WIRTGEN GROUP. The Operations Center\* - the digital platform for process, machine and service optimization - enables you to not only simplify maintenance planning for your machines, but also to increase your productivity and cost-effectiveness.

> [www.wirtgen-group.com/telematics](http://www.wirtgen-group.com/telematics)

\* The John Deere Operations Center™ (formerly WITOS) is currently not available in all countries. Please consult your responsible subsidiary or dealer if you have any questions.





# CRUSHING TECHNOLOGY

The right wear parts for the best results.

The versatile application areas of a KLEEMANN impact crusher range from classic natural stone processing through the recycling of residual construction material and on to mining

applications. The focus here is mainly on two tasks: To increase the service life of the wear parts and, at the same time, to lower operating costs.

- 01** Rubber curtain
- 02** Chain curtain
- 03** Wear plates
- 04** Rotor
- 05** Rotor ledges
- 06** Impact plates
- 07** Impact toggle
- 08** Impact bars
- 09** Rubber guard for crusher outlet

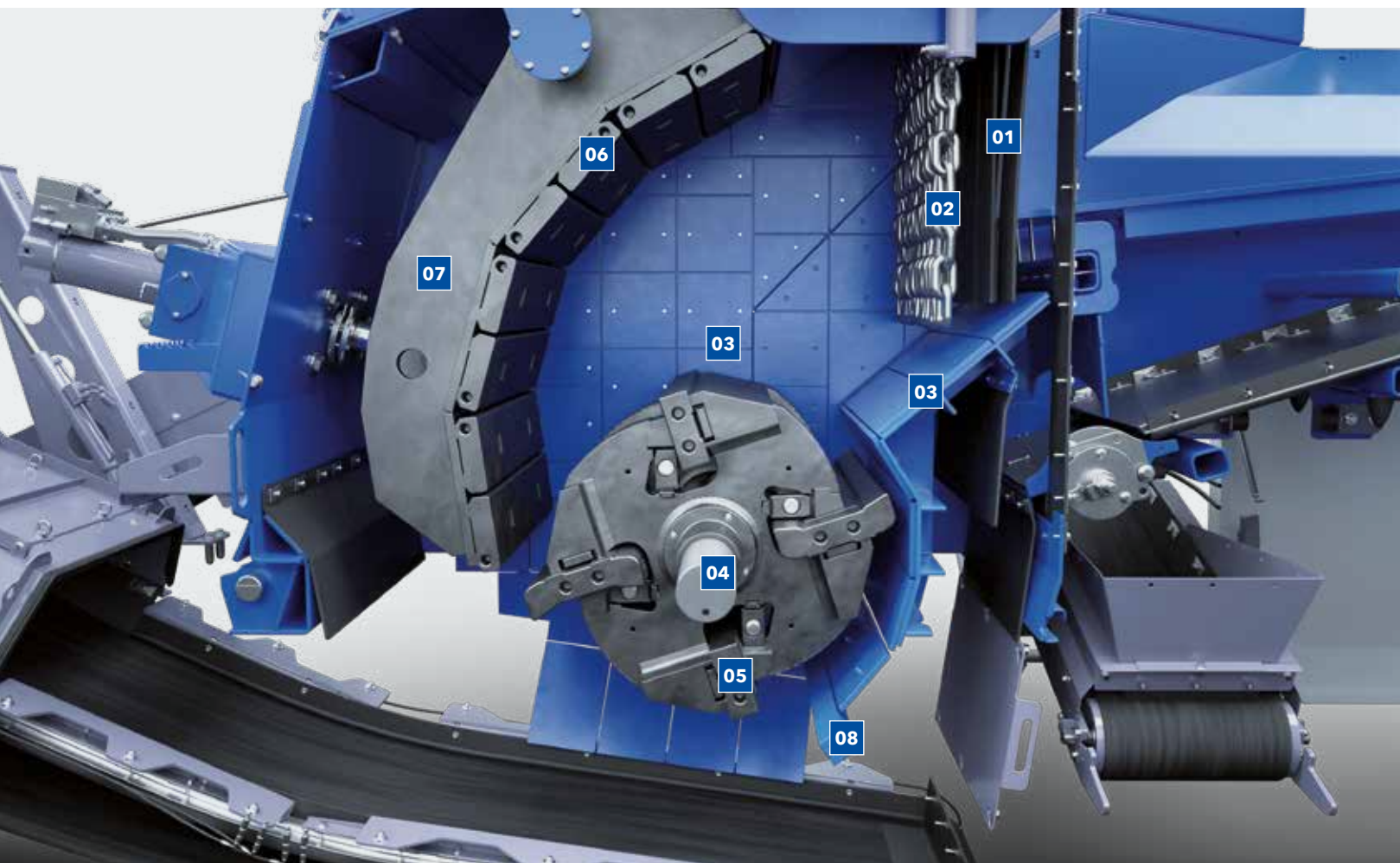

## C-shape rotor ledges

The C-shape rotor ledges are secured conveniently on the rotor via a lug on the rotor ledges. Depending on the application, they are available in different qualities.

- Martensitic steel with ceramic liners: C-TRON.MC+ (standard equipment)
- Chromium: C-TRON.C
- Chromium with ceramic liners: C-TRON.CC

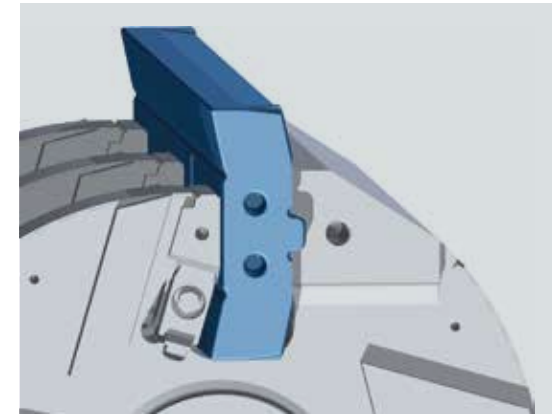

C-shape rotor ledge

## Wear lining

To protect the high-quality crusher housing against damage, it is completely panelled with highly wear-resistant plates (KRS).

Depending on the feed material, material stress can vary considerably. To reduce replacement times and wear costs, KLEEMANN offers the wear plates KRS.40 (hardness 430 HV),

KRS.50 (hardness 530 HV) and KRS.60 (hardness 600 HV). With the use of special hard-face welded wear plates (KRS.HW), the service life can be increased once again considerably.

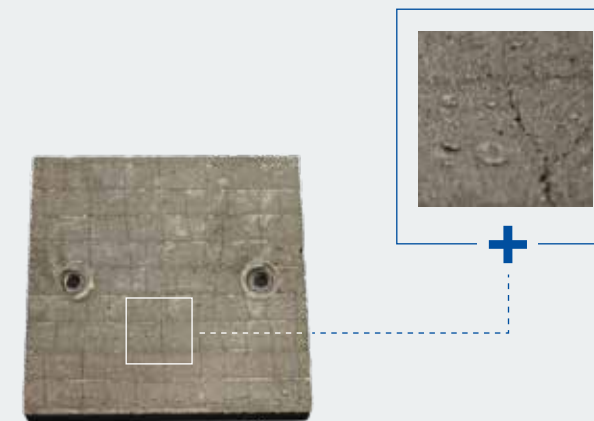

Surface of plates for inside of crusher. Cracks are a prerequisite for optimal hardness.

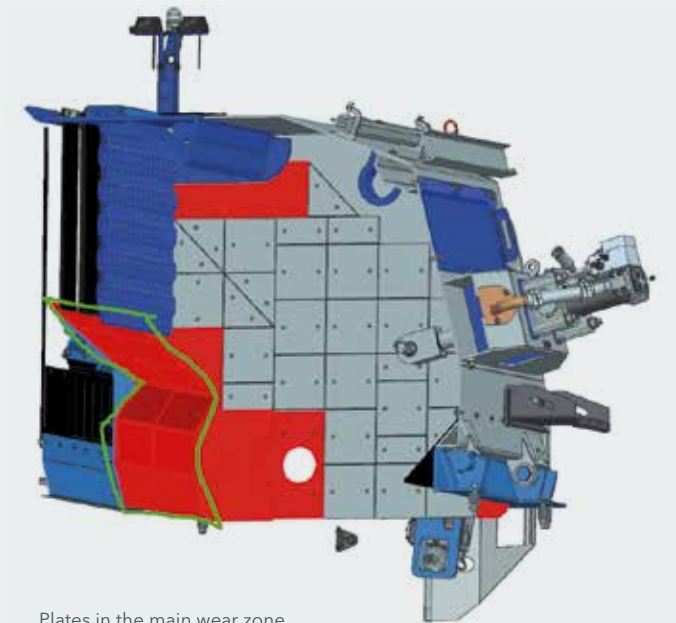

Plates in the main wear zone



# ROTOR LEDGES

The originals.

The cost-effective use of rotor ledges is influenced by factors such as the feed material, rotor speed, material moisture content, feed size and reduction ratio. Depending on the application field and material properties, different rotor ledges are available to achieve optimum results.

### Important questions for selecting application-specific blow bars

- > What type of material is being crushed?
- > How can the feed size be classified?
- > What is the range of abrasiveness?
- > Does the material contain uncrushable elements?

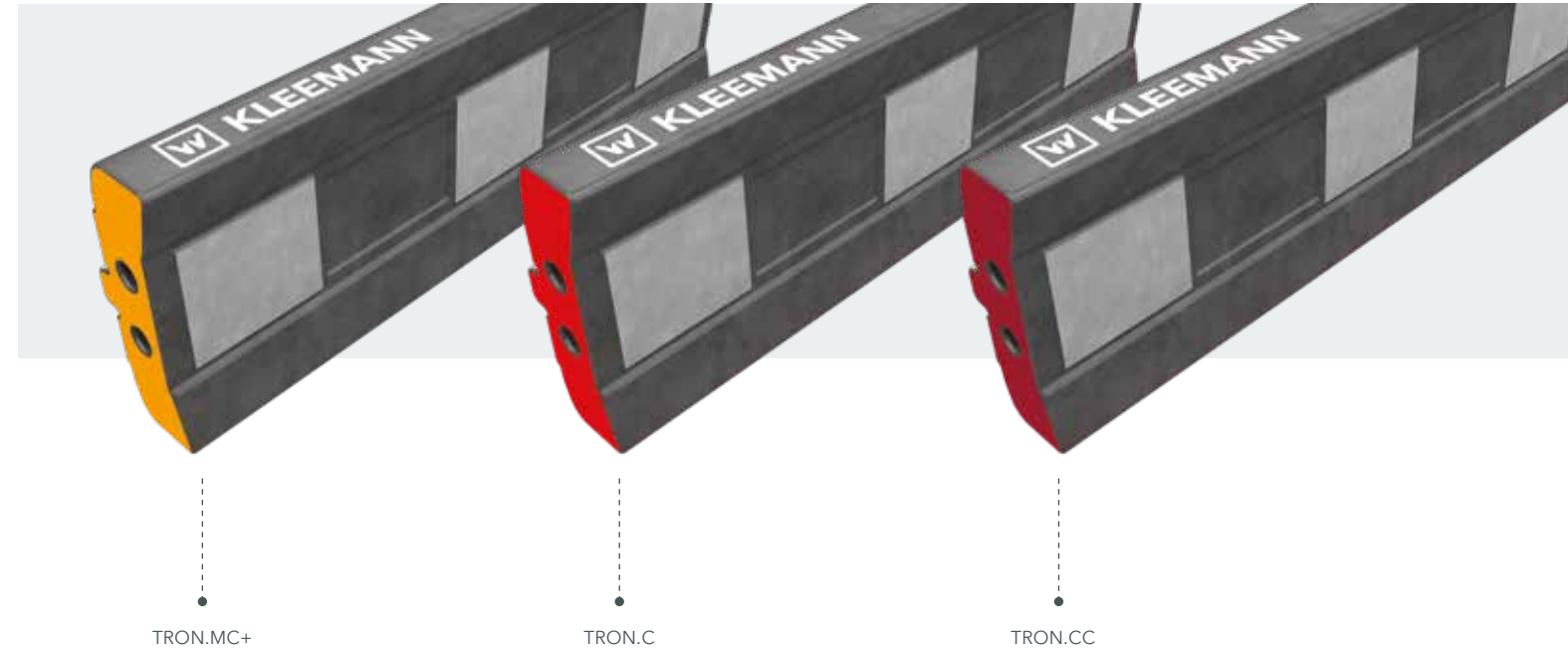

### ROTOR LEDGES PORTFOLIO FOR THE MR 100i NEO

	Material	Quality	Recommended application
C-TRON.MC+	Martensitic steel with ceramic liner	The rotor ledge consists of a martensitic steel body internally reinforced with ceramic liners on the inside. This composite material combines the hardness of ceramics with the mechanical properties of steel and has a 2 to 4 times longer service life compared to rotor ledges made from single alloys.	<ul style="list-style-type: none"> <li>&gt; Recycling mixed rubble with medium iron content</li> <li>&gt; Concrete</li> <li>&gt; Natural stone</li> <li>&gt; Asphalt</li> </ul>
C-TRON.C	Chrome steel	Chrome steel is characterized in particular by its extreme hardness and has the advantage of being very wear resistant, whereas manganese steel or martensitic steel rotor ledges would wear out too quickly.	<ul style="list-style-type: none"> <li>&gt; Recycling of mixed rubble and concrete with low iron content</li> <li>&gt; Maximum feed size 20" with crushability of &lt; 40%</li> <li>&gt; Maximum feed size 16" with crushability of &lt; 30%</li> <li>&gt; Medium hard to abrasive natural stone</li> <li>&gt; Asphalt</li> </ul>
C-TRON.CC	Chrome steel with ceramic liner	The combination of the chrome steel body and ceramic liners ensures a constant wear profile when processing highly abrasive pre-crushed materials as encountered especially in gravel pits and quarries.	<ul style="list-style-type: none"> <li>&gt; Secondary crushing stage for extremely abrasive natural stone or river gravel</li> <li>&gt; Asphalt with smaller feed size (smaller than 14")</li> </ul>



# TECHNICAL DATA AT A GLANCE

MOBIREX MR 100i NEO



## TECHNICAL DATA

### MR 100i NEO / NEOe

- > Crusher inlet (W x D): 40" x 30"
- > Feed capacity: up to 276 US t/h
- > Weight: min. 64,050 lbs

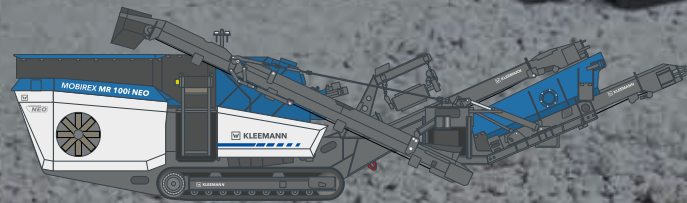





# KLEEMANN



## WIRTGEN AMERICA

6030 Dana Way  
Antioch, TN 37013  
USA

T: +1 615 501 0600

M: [info.america@wirtgen-group.com](mailto:info.america@wirtgen-group.com)

 [www.wirtgen-group.com/america](http://www.wirtgen-group.com/america)