

A WIRTGEN GROUP COMPANY



KLEEMANN



MOBIREX EVO2

MOBILE IMPACT CRUSHER MR 110i EVO2 | MR 130i EVO2



> THE POWERFUL ALL-ROUNDER



MOBIREX MR 110i | 130i EVO2

Whether in the quarry or for recycling - the MOBIREX MR 110i/130i EVO2 impact crushers crush feed material efficiently and produce top product quality. Simple transport, short set-up times and high machine availability make them the ideal all-rounders - even with work sites that change at short notice.



Focus on flexibility



Efficiency in the foreground



Operability at a glance



MOBIREX MR 110i | 130i EVO2

MR 110i EVO2 hopper volume:
5.8 yd³, 10.5 yd³ with extension

MR 130i EVO2 hopper volume:
6.5 yd³, 11.8 yd³ with extension

Single-deck vibrating screen and
double-deck vibrating screen



SPECTIVE
CONNECT

+ Option

1 Feeding unit

4 Crusher unit

7 Post screening unit and magnetic separator

2 Prescreening

5 Drive

> Material flow

3 Continuous Feed System CFS

6 SPECTIVE control system

> Handling and sustainability

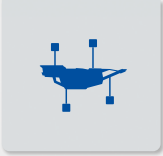

1 Feeding unit

- > Generously dimensioned basic hopper for simple and fast loading
- > Can be folded and locked hydraulically - for faster set-up from the ground via radio remote control

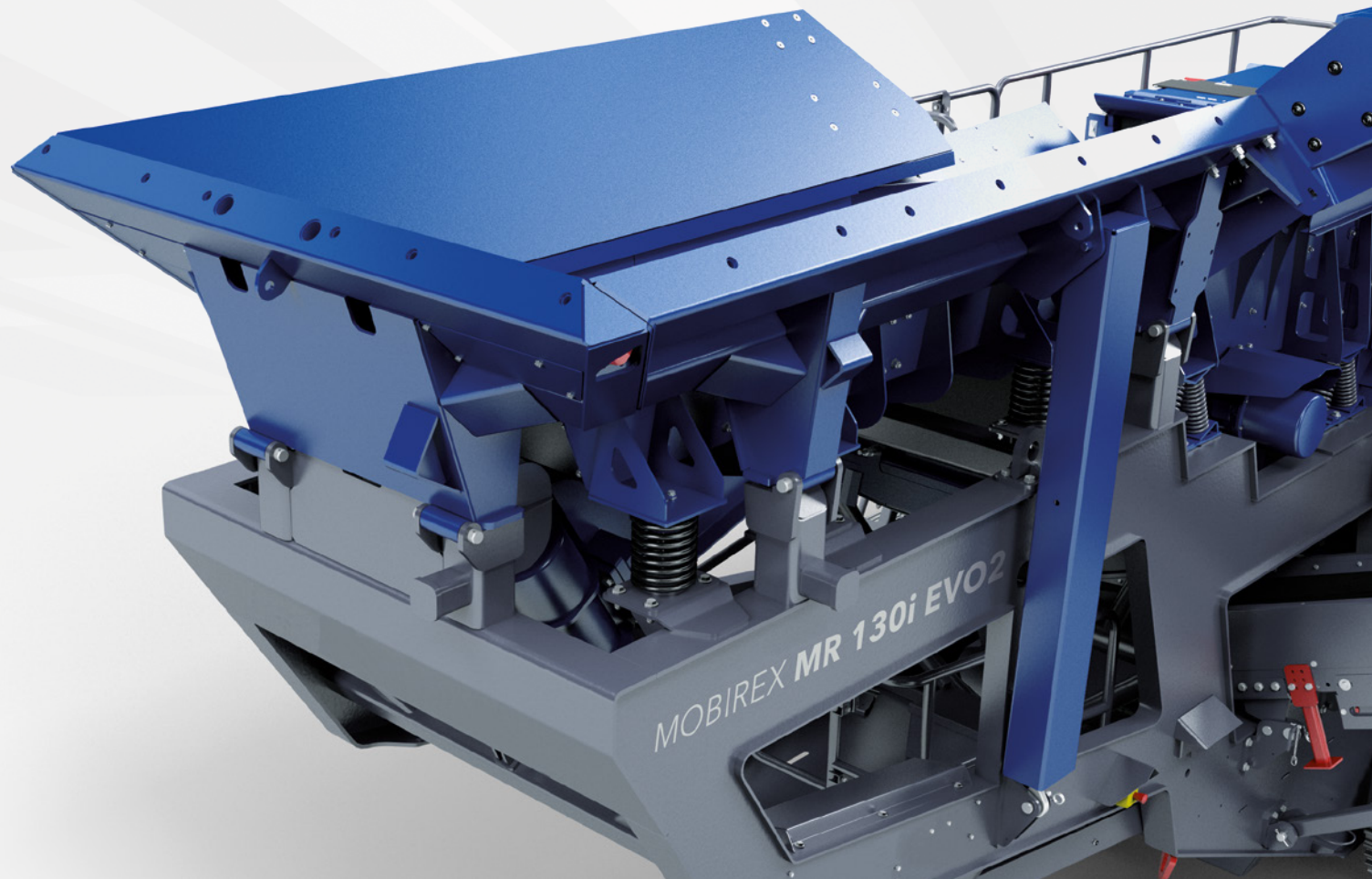

1 Feeding unit

2 Prescreening

3 Continuous Feed System CFS

4 Crusher unit

5 Drive

6 SPECTIVE control system

7 Post screening unit and magnetic separator

> Material flow

> Handling and sustainability

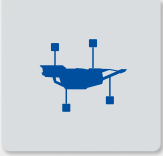

2 Prescreening

- > Independently vibrating double-deck prescreening guarantees effective screening of fine material for optimal final product quality
- > Reduction in wear is achieved by redirecting medium-sized grain through the large crusher bypass
- > Discharge of fines via the side discharge conveyor⁺; conveyor can be installed flexibly on the right or left, rigid or hydraulically foldable



⁺ Option

1 Feeding unit

2 Prescreening

3 Continuous Feed System CFS

4 Crusher unit

5 Drive

6 SPECTIVE control system

7 Post screening unit and magnetic separator

> Material flow

> Handling and sustainability

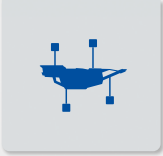

3 Continuous Feed System CFS

- > Continuous crusher load through the intelligent CFS feed control:
 - > Based on crusher and engine utilization, the material feed is adjusted continuously and without a delay by the vibrating feeder and prescreen
- > Less burden is placed on the downstream components, wear is also reduced and the share of oversize grain is minimized

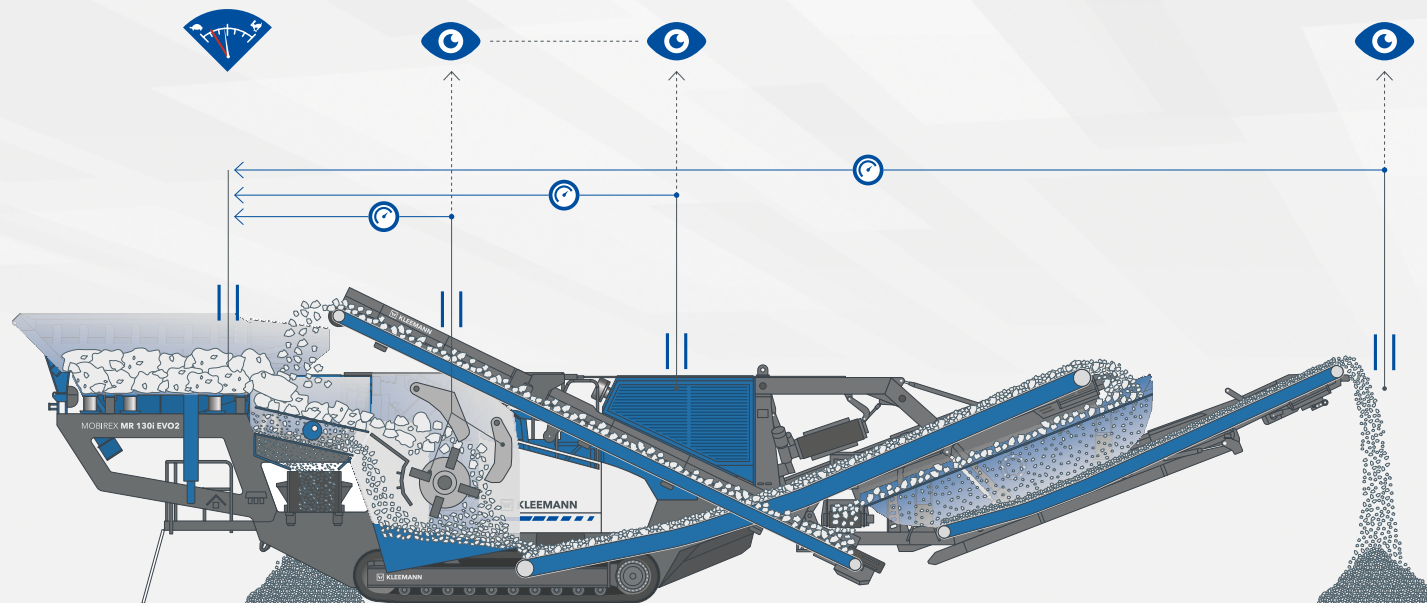

1 Feeding unit	4 Crusher unit	7 Post screening unit and magnetic separator
2 Prescreening	5 Drive	> Material flow
3 Continuous Feed System CFS	6 SPECTIVE control system	> Handling and sustainability



4 Crusher unit

- > Optimal inlet geometry for improved material feed behaviour and therefore increased throughput
- > Fewer blockages in the crusher inlet area thanks to the crusher inlet cover which can be raised hydraulically and the upper impact toggle (radio-controlled)
- > Increased product quality thanks to C-shape rotor ledges for better impact over long periods

Fully hydraulic gap adjustment and overload system

- > Automatic zero-point determination for precise gap setting via touch panel
- > The effective overload system opens the lower impact toggle in the event of uncrushable elements and then moves back automatically to the preset value
- > As a final safety feature, a bursting disc protects the crusher against excessively large uncrushable elements



1 Feeding unit

2 Prescreening

3 Continuous Feed System CFS

4 Crusher unit

5 Drive

6 SPECTIVE control system

7 Post screening unit and magnetic separator

> Material flow

> Handling and sustainability

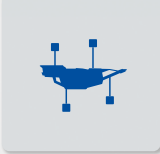

5 Drive

 Efficient and powerful D-DRIVE diesel-direct drive with low fuel consumption, conveyors are driven electrically

> Heat package⁺ (5 to 122 °F) or cold package⁺ (-13 to 104 °F)



KLEEMANN SUSTAINABILITY describes innovative technologies and solutions which are consistent with the sustainability objectives of the WIRTGEN GROUP.

⁺ Option

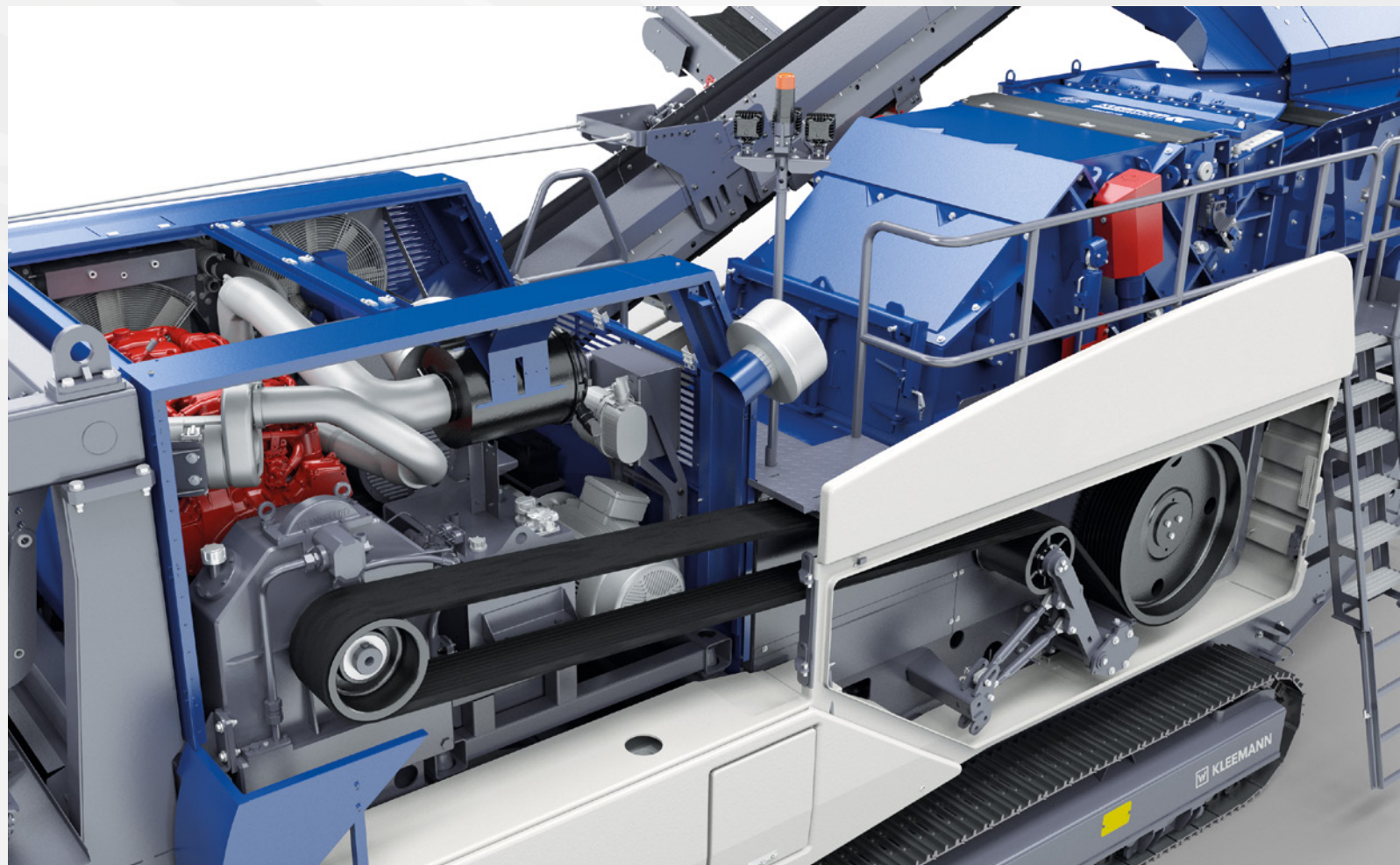

1 Feeding unit

2 Prescreening

3 Continuous Feed System CFS

4 Crusher unit

5 Drive

6 SPECTIVE control system

7 Post screening unit and magnetic separator

> Material flow

> Handling and sustainability

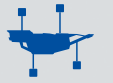

6 SPECTIVE control system

- > **SPECTIVE touch panel:** with menu-guided operation, visualization and support; status display of all components such as speed, temperature, etc., rapid fault localization and diagnostics
- > **SPECTIVE CONNECT⁺:** all important information is displayed directly on the smartphone
- > **Telematics system:** efficient fleet and service management with information on the plant's operating status regardless of location and time
- > **Quick Track:** fast and simple shifting of the machine to operating mode; operation takes place conveniently via the remote control

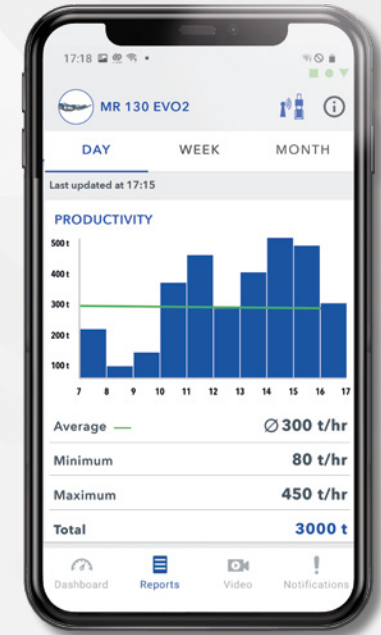

 SPECTIVE

 SPECTIVE
CONNECT

+ Option

1 Feeding unit

2 Prescreening

3 Continuous Feed System CFS

4 Crusher unit

5 Drive

6 SPECTIVE control system

7 Post screening unit and magnetic separator

> Material flow

> Handling and sustainability

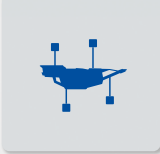

7 Post screening unit and magnetic separator

> **Post screening unit** available in two versions:

- > Single-deck vibrating screen for the production of a classified final grain size
- > Double-deck vibrating screen⁺ for the production of two classified final grain sizes (only for the MR 110i EVO2)

> Return conveyor for closed material loop; 100° swivel-mounted for side discharge

> The wind sifter⁺ guarantees increased material quality, removal of contamination (e.g. wood and plastic), air flow setting according to the material, 2nd wind sifter⁺ available with the optional double-deck post screening unit

Magnetic separator

- > High-performance electromagnet⁺ or permanent magnet for maximum output
- > Stepless raising and lowering parallel to crusher discharge conveyor; radio control is also possible



⁺ Option

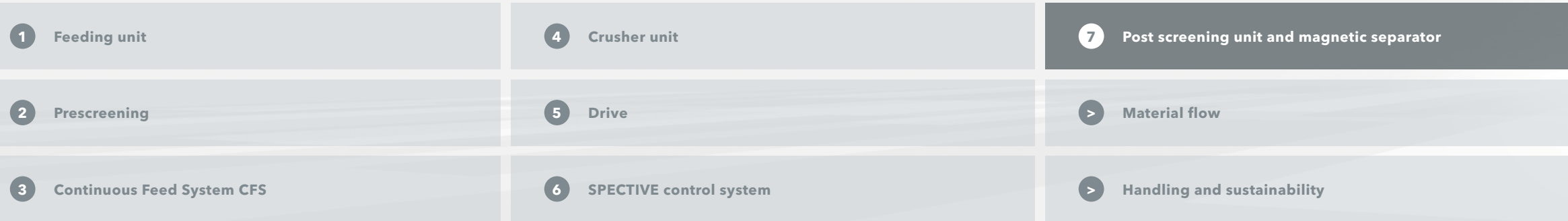

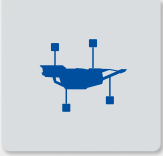

> Optimized material flow

- > Tried-and-tested material flow concept: extension of system widths across all components in the direction of material flow; the material flow is not narrowed
- > Prevention of material congestion

- > Higher total throughput with lower fuel consumption
- > Longer service life thanks to reduced wear

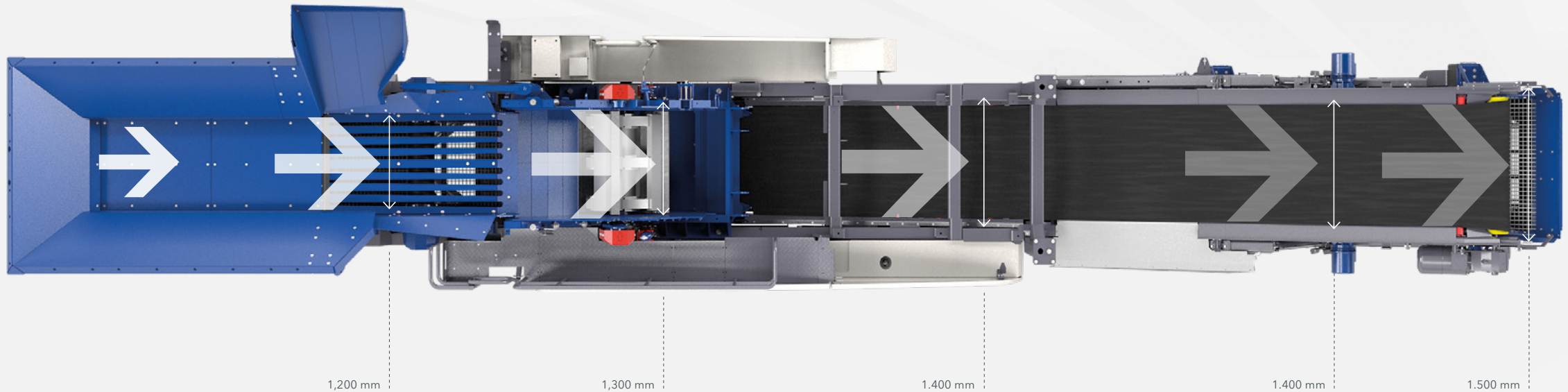

1 Feeding unit	4 Crusher unit	7 Post screening unit and magnetic separator
2 Prescreening	5 Drive	> Material flow
3 Continuous Feed System CFS	6 SPECTIVE control system	> Handling and sustainability

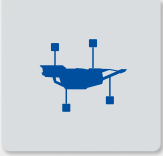

> Transport

- > Increased ground clearance in the area of the post screening unit for better transportability
- > Simple disassembly of the post screening unit for individual transport

> Safety and ergonomics

- > Quick and convenient servicing thanks to easy physical and visual access to all components
- > Spray system and LED lighting for extended illumination of work areas included in basic plant; premium lighting⁺

Lock & Turn safety system

- > The key transfer safety permits work in certain areas of the crusher only if they are mechanically secured
- > Lock: the rotor Lock & Turn safety system secures the rotor and guarantees safe maintenance
- > Turn: simple positioning of the rotor by the turning device

> Environment

- > Environmentally-compatible solutions for reducing noise and dust
- > Solutions for noise reduction⁺: insulation of the noise sources via an ergonomic power pack housing, reduction of noise by 6 decibels (3 decibels are the equivalent of a reduction of 50 % for the human ear)
- > Solutions for dust containment: an effective spray system at different material transfer points of the plant, e.g. crusher inlet, crusher discharge conveyor, side discharge conveyor, post screening unit



⁺ Option

1 Feeding unit

2 Prescreening

3 Continuous Feed System CFS

4 Crusher unit

5 Drive

6 SPECTIVE control system

7 Post screening unit and magnetic separator

> Material flow

> Handling and sustainability

TECHNICAL INFORMATION	MR 110i EVO2	MR 130i EVO2
Feed capacity up to approx. (US t/h)	386 ¹⁾	496 ¹⁾
Crusher inlet (W x H) (inch)	44" x 31"	52" x 36"
Max. feed size (inch)	35" x 22"	41" x 26"
Transport height without options (inch)	11' 10"	12' 4"
Transport length without options (inch)	56' 11"	60' 4"
Transport width without options (inch)	9' 10"	9' 10"
Transport length with single-deck screening unit (inch)	69' 3"	70' 11"
Transport width with single-deck screening unit (inch)	10'	10' 4"
Transport weight of single-deck screening unit (lbs)	13,450	14,340
Transport weight of basic plant - max. configuration (lbs)	120,150 - 133,500	132,300 - 140,550

¹⁾ Depending on type and composition of feed material, feed size, primary screening as well as target final grain size



WIRTGEN AMERICA

6030 Dana Way
 Antioch, TN 37013
 USA

T: +1 615 501 0600

M: info.america@wirtgen-group.com

▶ www.wirtgen-group.com/america