

Technical information

SUPER 1703-3i



Wheeled paver SUPER 1703-3i

Universal Class

TECHNICAL HIGHLIGHTS

- > Maximum paving width 19 ft. 6 in. (5.95 m)
- > Maximum laydown rate 770 tons/h (700 tonnes/h)
- > Transport width 8 ft. 6 in. (2.59 m)
- > Engine output: 173 hp (129 kW) at 2,000 rpm

SUPER 1703-3i - the most innovative paver technology

The wheeled SUPER 1703-3i has been designed for the requirements especially of the North American and Australian markets. Thanks to the compact size of the paver in the 8-foot class, it is ideal for commercial and municipal applications. For the wheeled machine, the drive options 6x4 and 6x6 are available.

The SUPER 1703-3i also comes with the popular ErgoPlus 3 operating system, which has been enhanced with a number of ergonomic and functional features.



TECHNICAL DATA

Power unit

Engine	
> Version	4-cylinder diesel engine, liquid-cooled
> Manufacturer	Cummins
> Type	QSB4.5 - C173
Output	
> Nominal	173 hp (129 kW) at 2,000 rpm (according to DIN)
> ECO mode	160 hp (119 kW) at 1,700 rpm
Emissions information	
> Exhaust emissions standards	EU Stage 4, US EPA Tier 4f
> Exhaust gas after-treatment	DOC, SCR
Fuel tank	57 gallons (US) (215 liters)

Undercarriage

Front wheels	
> Version	4, mounted on bogies (oscillating axle)
> Tire equipment	solid tires
> Tire size	540/300 - 390 mm
Rear wheels	2, pneumatic tires, tubeless
> Tire size	14.00 R25
Traction drive	separate hydraulic drive provided for each wheel
> Standard	2 rear wheels and 2 front wheels powered (6x4)
> Option	2 rear wheels and 4 front wheels powered (6x6)
Speeds	
> Paving	up to 250 fpm (76 m/min.), infinitely variable
> Transport	up to 12 mph (20 km/h), infinitely variable
Outside turning circle	minimum of 11 ft. 6 in. (3.5 m) with Pivot Steer

Material hopper

Hopper capacity	14.3 tons (13 tonnes), including conveyor tunnel
Width	10 ft. 9 in. (3,265 mm)
Feed height	24 in. (615 mm)
Push-rollers	
> Standard	oscillating
> Position	can be displaced forwards by 3 in. (75 mm) or 6 in. (150 mm)
> Option	truck hitch

Conveyors and augers	
Conveyors	
> Version	2, with replaceable feeder bars, conveyor movement reversible for a short time
> Drive	separate hydraulic drive provided for each conveyor
> Speed	up to 130 fpm (40 m/min.), infinitely variable (manual or automatic)
Augers	
> Version	2, with exchangeable auger blades, auger rotation reversible
> Diameter	16 in. (400 mm)
> Drive	separate hydraulic drive provided for each auger
> Speed	up to 120 rpm, infinitely variable (manual or automatic)
> Height	infinitely variable by 6 in. (15 cm), hydraulic
Lubrication	automatic centralized lubrication system with electrically driven grease pump
Screed	
	VF 500
Basic width	8 ft. to 15 ft. 6 in. (2.45 m to 4.75 m)
Maximum width	19 ft. 6 in. (5.95 m)
Compacting systems	V
Layer thickness	up to 12 in. (30 cm)
Screed heating	
> Version	electric by heating rods
> Power supply	three-phase AC generator
Dimensions (transport) and weights	
Length	
> Version	tractor unit and screed
> VF 500 V	19 ft. 7 in. (5.96 m)
Weights	
> Version	tractor, hardtop and screed
> VF 500 V	38,140 lbs. (17.3 tonnes)

Key: DOC = Diesel Oxidation Catalyst, SCR = Selective Catalytic Reduction, VF = Screed with Front-Mounted Extensions, V= with vibration

SIDE AND FRONT VIEW

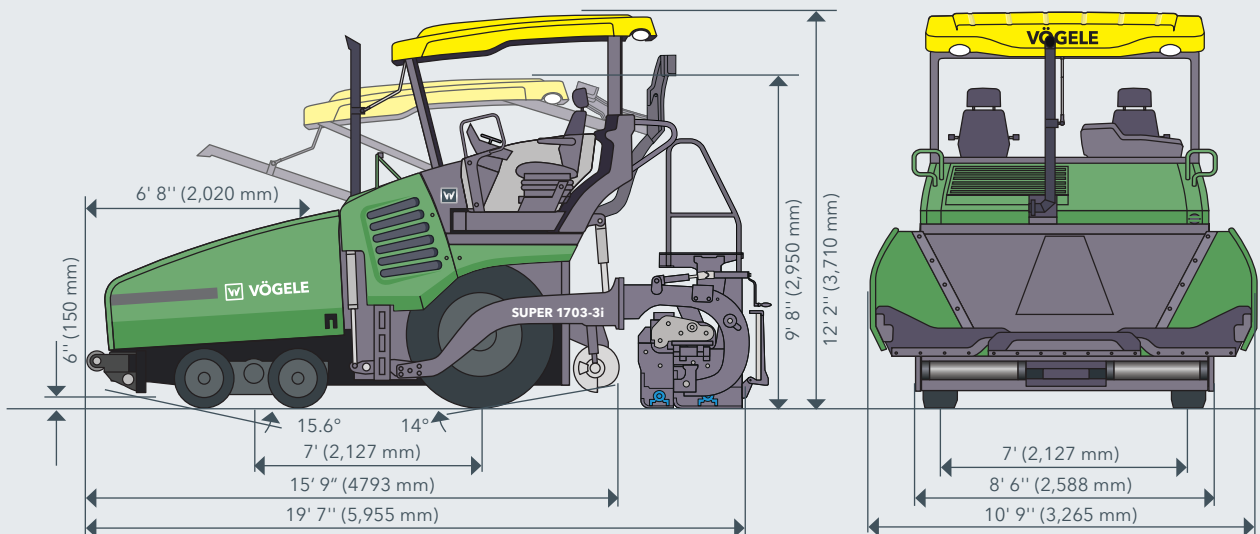

THE HIGHLIGHTS OF THE SUPER 1703-3i

- > Wheeled Universal Class paver with a large range of applications and pave widths up to 19 ft. 6 in. (5.95 m)
- > Powerful engine complying with US EPA standard Tier 4f
- > The VÖGELE EcoPlus low-emissions package significantly reduces fuel consumption and noise levels
- > Optimum feeding with mix thanks to the large material hopper holding 14.3 tons (13 tonnes)
- > ErgoPlus 3 with a number of additional ergonomic and functional advantages
- > The Pivot Steer steering brake reduces the outside turning circle to 11 ft. 6 in. (3.5 m)
- > Fully-integrated Niveltronic Plus, the System for Automatic Grade and Slope Control
- > High paving speeds up to 250 fpm (76 m/min)

FEATURES

> Large receiving hopper holding 14.3 tons (13 tonnes)	■
> Hydraulic hopper front	■
> Truck hitch	□
> Simple, ergonomic ErgoPlus 3 operating concept	■
> Working lights, LED	■
> Pivot Steer steering brake (Standard)	■
> Powerful oil-cooled generator	■
> VÖGELE EcoPlus low-emissions package	■
> LED light balloon for use at night	□
> NEMA power outlet, 120 V	□
> Sonic sensor to control augers	■
> Power Tunnel - hydraulically adjusted limiting plates for auger tunnel	■
> Niveltronic Plus System for Automated Grade and Slope Control	■
> Various sensor types are available for the Niveltronic Plus	□
> VÖGELE RoadScan comprehensive asphalt temperature measuring system	□
> WITOS Paving FleetView Telematics System	■
> Ventilation System	■

This list is just an extract of the scope of supply.
Standard features and options may differ by sales region.

■ Standard feature □ Option

Wirtgen America, Inc.

6030 Dana Way
Antioch, TN 37013
USA

T: +1 615 501-0600
F: +1 615 501-0691
M: info.america@wirtgen-group.com

➤ www.wirtgen-group.com/america

